



Rail

PARTNER IN  
POWERFUL SOLUTIONS.

PAST.  
PRESENT.  
FUTURE.

**100**

Shaping the rail industry for 100 years.



A Rolls-Royce  
solution





# CONTENTS

<b>01 Pioneering the power that matters</b>	4 - 5	<b>04 Automation solutions</b>	
		Optimal drive system control	28
<b>02 Lifecycle solutions provider</b>		Enhanced automation functions	29
100 years of solutions	6 - 7	Repowering solutions	30 - 31
Backing your power all the way	8 - 11		
Applications overview	12 - 13	<b>05 Green technologies and fuels</b>	
		Engineering today what you'll need tomorrow	32 - 33
<b>03 Drive solutions for railcars, push-pull trains and locomotives</b>		Emission reduction solutions	34 - 35
Efficient. Effective. Eco-friendly.	14 - 15	HVO - Your fast track ticket to lower emissions	36 - 37
PowerPacks for roof and underfloor installation	16 - 17	Series emissions certifications	38 - 39
System solutions and engines for engine room installation	18 - 19		
		<b>06 mtu service solutions</b>	
<b>Drive solutions for railcars and locomotives - references</b>		A lifetime of value	40
Railcars	20	Extended coverage	41
Locomotives	21	<b>mtu</b> ValueCare Agreements	42 - 43
PowerPacks - compact, complete and cost-efficient	22 - 23	Digital solutions	44 - 45
		Reman/overhaul solutions	46
<b>Drive solutions for push-pull trains and locomotives</b>		Preventive maintenance	47
System solutions with Series 4000:		Support services	48 - 49
All-round overachievers	24 - 25		
Performance overview: Engines and PowerPacks	26 - 27		

**1 UK | 700 kW / 939 bhp**  
 Hitachi Rail  
 Dependability for over 27 years - Intercity Express Programme trains with **mtu** PowerPack Series 1600 backed by **mtu** ValueCare agreements

**2 New Zealand | 2,700 kW / 3,620 bhp**  
 CRRC  
 63 locomotives equipped with **mtu** engines operate reliably, cost-effectively while keeping emissions to a minimum

**3 UK | 375-390 kW / 503-523 bhp**  
 CAF  
 Some 450 compact, lightweight and efficient **mtu** PowerPack Series 1800 keep Civity regional passenger trains operating on schedule

**4 USA | 900-2,400 kW / 1,207-3,218 bhp**  
 KLW  
 30 locomotives with **mtu** diesel engines and OEM aftertreatment systems achieve Tier 4 benchmark as the cleanest in the US





# PIONEERING THE POWER THAT MATTERS.

# 01

We at Rolls-Royce provide world-class power solutions and complete life-cycle support under our product and solution brand **mtu**. Fully utilizing the potential of digitalization and electrification, we strive to develop climate-neutral drive and power generation solutions that are even cleaner and smarter and thus provide answers to the challenges posed by climate change and the rapidly growing societal demands for energy and mobility. We deliver and service comprehensive, powerful and reliable systems, based on both gas and diesel engines, as well as electrified hybrid systems.



### A solution provider

**mtu** systems power the strongest tugboats, the most modern yachts and the biggest land vehicles and provide energy for the world's most important mission-critical applications. With advanced solutions such as microgrids we integrate renewable energies and manage the power needs of our customers.

### An expert in technology

**mtu** products are known for cutting-edge innovation and technological leadership. That same spirit of innovation inspires our sustainability efforts. Our focus is on developing and implementing system solutions that both maximize efficiency and reduce emissions – which in turn helps to reduce our impact on the environment.

For over 110 years we have provided innovative solutions for our customers – meeting even the most demanding drive and power requirements. Our products and services span a wide range of applications and power needs, with both standard and customized options.

### A passionate and reliable partner

We at Rolls-Royce spend every day working together with our customers, to deliver engines, systems and complete life-cycle solutions that best fit their needs. We understand that each application is different and has its own specific demands. Our engineers embrace the challenge of finding the perfect solution for your unique power requirements. Every step of the way – from project planning, through design, delivery and commissioning; to the lifetime care of your equipment – we are dedicated to helping you get the most from your **mtu** investment.

OVER  
**20,000**  
DRIVE SOLUTIONS  
FOR RAIL VEHICLES SINCE 1950



- 1 **Resourceful**  
We are highly skilled at devising quick, intelligent ways to fulfill customers' needs.
- 2 **Responsible**  
We develop innovative technologies that also meet the highest emission standards.

- 3 **Reliable**  
We can be counted on to find the perfect solution for any requirement at every step.



Lifecycle solutions provider

# 100 YEARS OF SOLUTIONS.

# 02

Designing and developing customized solutions has a long tradition for us. Karl Maybach introduced the first diesel engine for railcars back in 1924 already, bringing forth such milestone achievements as the “Fliegender Hamburger,” the fastest passenger train of its time.

Agility, flexibility and the ability to come up with customized solutions that precisely fit the individual needs of rail clients have always been signature hallmarks of our company. In close cooperation with

customers, totally immersed in their daily operations, we push ourselves to design and develop the absolute best technological, economical and ecological answers for addressing their challenges.





Lifecycle solutions provider

## BACKING YOUR POWER ALL THE WAY.

Although transport today comprises many different modes, rail continues to be the backbone of mobility. Staying power also defines our solutions and commitment to clients. We are specialized in complete drive solutions that offer optimal performance over the entire course of their lifetime. We ensure that they do by optimally supporting clients with first-rate solutions for optimizing their applications – continually, from day one, at every phase. From consulting and planning to development and commissioning, uptime maximization, digital field support, tailored services and more, we have the perfect solution.

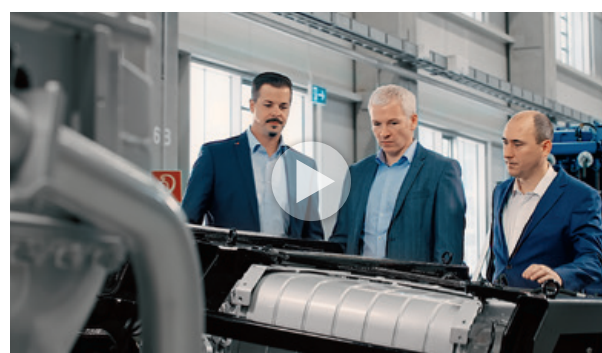

What makes **mtu**  
your ideal Lifecycle Solution partner?

Learn more by scanning the code.



### PLANNING AND DESIGN

- Expert consultation on available technology options
- Track profile simulations to determine most efficient drive solution (conventional or hybrid)
- Various calculations, e.g. tractive effort calculations
- Feasibility and installation studies
- Technical specifications documentation
- 3D models and drawings

### DEVELOPMENT AND COMMISSIONING

- Tailored and modular drive solutions – diesel, electric or hybrid
- Alignment throughout design and prototyping
- Extensive prototype testing (e.g. full-load test, noise and vibration measurements)
- Installation support
- Static and dynamic commissioning

### PRODUCT AND SECOND LIFE

- Tailored ValueCare Agreements (e.g. for parts availability, guaranteed uptime)
- Global support through our comprehensive service network
- Repower solutions to improve fuel savings, emissions reductions, availability and more
- Engine overhaul for increased performance
- Reman services for parts and entire drive solutions
- Connectivity and digital solutions free of charge during warranty time



## Applications overview

## SPECIFIC IS OUR SPECIALTY.

Every rail drive application is different and has its own very specific requirements. Specific is our specialty. Our engineers welcome the challenge of finding the perfect drive solution for your needs.

**Multiple-unit and high-speed trains**

Extremely powerful and proven in continuous service – our drive solutions feature an excellent power-to-weight ratio and outstanding operational availability, enabling them to deliver the reliability, punctuality and safety that passengers expect of multiple-unit and high-speed trains.

**Railcars**

Designed specifically for quick and easy underfloor and roof installation, our complete, compact drive systems incorporate all components in one highly reliable operational unit. They combine decades of experience with one-of-a-kind technologies as the perfect railcar drive solution.

**Shunting and industrial locomotives**

The drive system requirements of shunting and industrial locomotives are very special. Our engines are well designed for the task, thanks in part to their excellent part-load performance and acceleration characteristics.

**Mainline and multi-purpose locomotives**

Whether for heavy goods transport, high-speed transit or long-haul passenger routes, our drive systems deliver reliable performance – along with extended service intervals, maintenance-friendly design and reduced fuel consumption that keep life-cycle costs low.

**Special purpose rail vehicles**

From diesel-electric to diesel-mechanical, diesel-hydraulic, even diesel-hydrostatic – we have the perfect drive solution for all types of special purpose vehicles operating at extremely low speeds.



Drive solutions for railcars, push-pull trains and locomotives

EFFICIENT. EFFECTIVE.  
ECO-FRIENDLY.

Collaborating closely with customers, we work to develop solutions that deliver superb performance over the complete lifecycle of the drive systems. Our solutions are extremely efficient, effective and eco-friendly. They are also highly compact and easy to integrate.

03



Drive solutions for railcars, push-pull trains and locomotives

# POWERPACKS FOR ROOF AND UNDERFLOOR INSTALLATION.

Increasing demand for local public transportation has created a need for modern railcars that support eco-friendly transportation with latest drive technologies. As complete drive solutions, our innovative and highly compact PowerPacks® are well up to the task and are quickly and easily integrated into wide-ranging vehicles.

mtu PowerPacks are highly reliable drive systems that help to ensure smooth, on-time train operations. Combining fuel efficiency with extended service intervals and a maintenance-friendly design, they keep operating costs low.

Our Series 1800 and 1600 PowerPacks feature a particularly flat and compact design for easy underfloor or roof installation.

All drive components are contained in a single operational unit and can be individually configured.

We also offer railcar equipment for diesel-electric and diesel-mechanical power transmissions. If needed, we can adapt our systems, including the automation, to optimally fit your specific railcar needs.

**Benefits:**

- Continuous design improvements with the same footprint (modular strategy)
- Zero emissions operation on chosen stretches (with Hybrid PowerPack)
- Extensive roof and underfloor installation experience
- Repower capability to extend the life of your investment

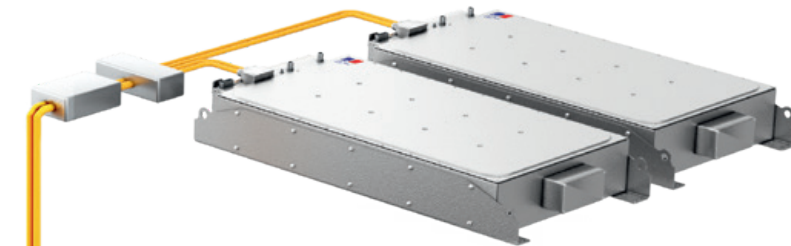

**Hybrid PowerPack with Series 1800**  
Optimal integration of all drive components in a slim and trim design to enable easy underfloor installation.  
315 - 470 kW (422 - 630 bhp)

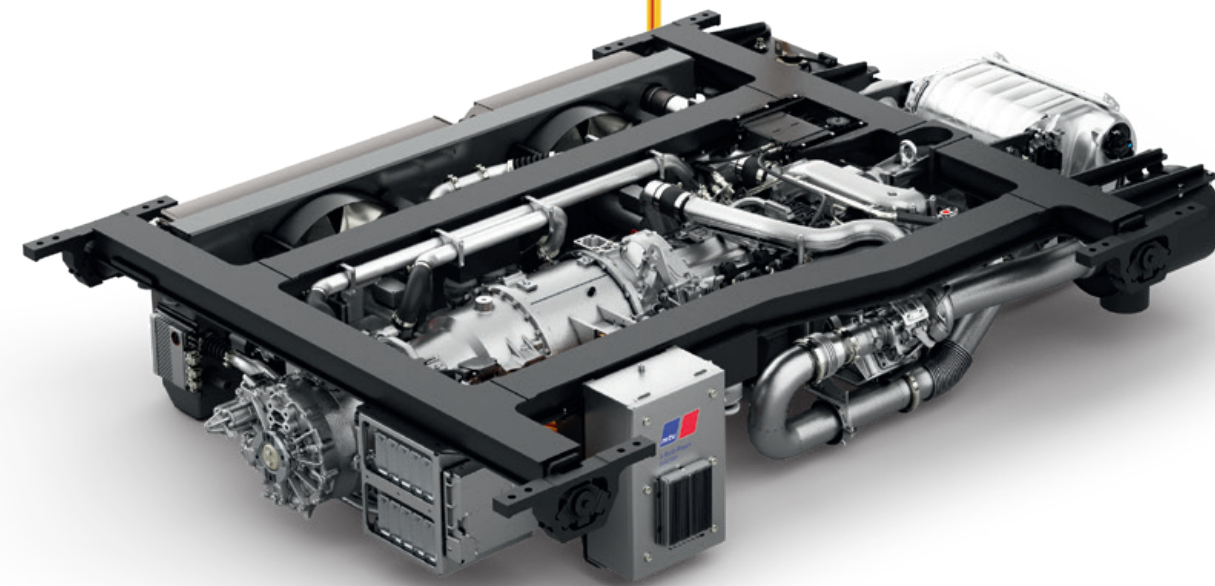

**PowerPack with Series 1600**  
Highly compact, integrated and powerful.  
565-736 kW (758-987 bhp)



**PowerPack with Series 1800**  
Over 20 years of reliable and efficient performance.  
315-390 kW (422-523 bhp)

# SYSTEM SOLUTIONS AND ENGINES FOR ENGINE ROOM INSTALLATION.

Our diesel push-pull, all-purpose and mainline drive solutions are specifically designed for heavy freight and high-speed passenger trains. Our locomotive diesel drives, on the other hand, have been optimized for shunting and industrial units involving frequent load changes in all partial load areas and high time slices with low loads. All of our

locomotive drive solutions are engineered for maximum uptime, high reliability, easy maintenance, long times between overhaul (TBO) and low life-cycle costs. They combine low emissions and fuel efficiency with a lightweight design for good overall value.

**System solutions with Series 4000**  
The perfect example for clean and durable operation, tried and tested in well over 3,000 applications worldwide.  
1,000 - 3,300 kW (1,341 - 4,425 bhp)

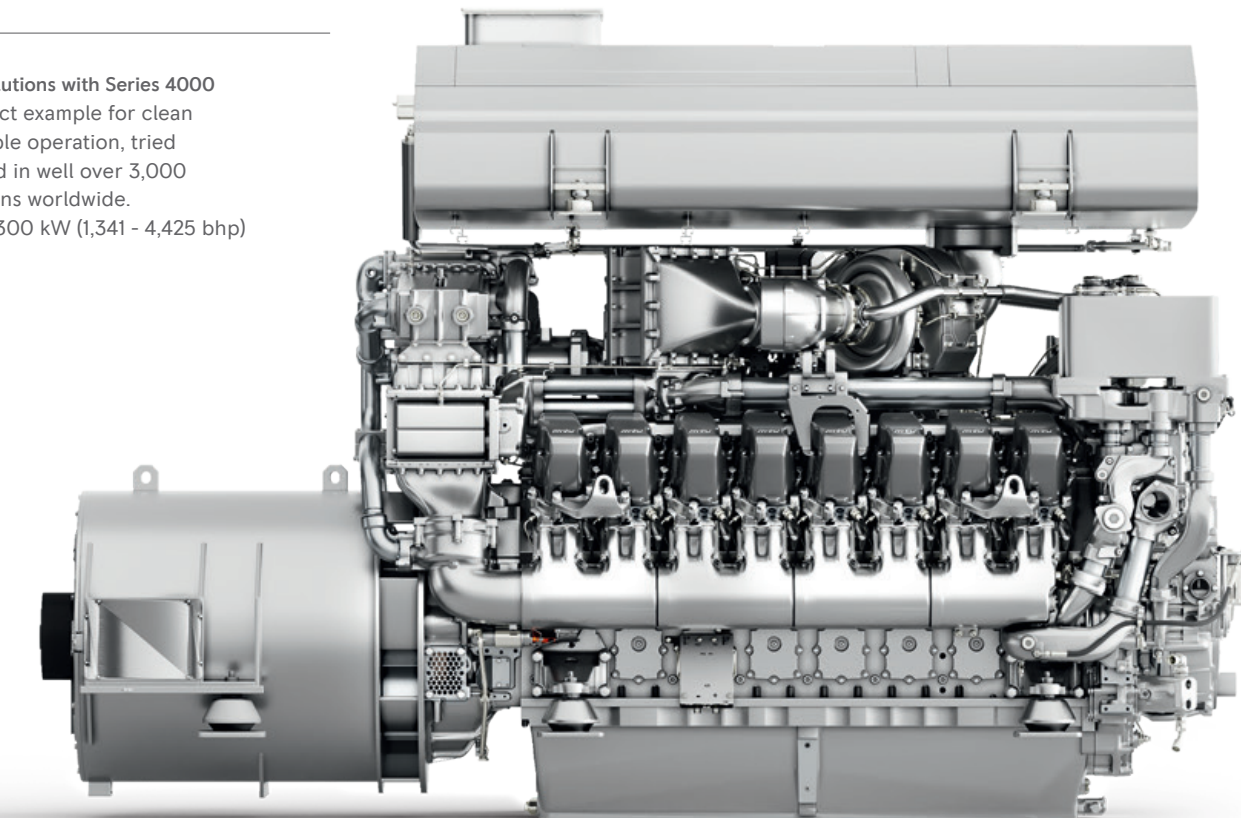

**Series 1500\***  
Tireless performance and optimized fuel efficiency in one. Can be operated with synthetic fuels.  
380-480 kW (510-644 bhp)

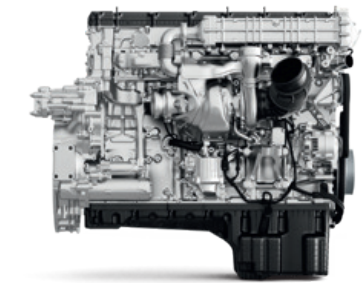

**Series 1300\***  
Highly efficient design, ideal for shunting and multi-engine locomotives, railcars. Can be operated with synthetic fuels.  
320-390 kW (429-523 bhp)

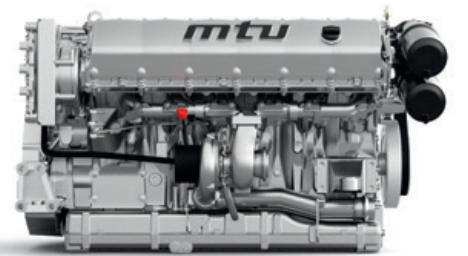

**Series 1600**  
Extremely compact rail engine for smooth operation and extremely low emission values.  
565-736 kW (758-987 bhp)



**Series 2000\***  
Durable components, dependable performance, day in and day out.  
783-1,163 kW (1,050-1,560 bhp)

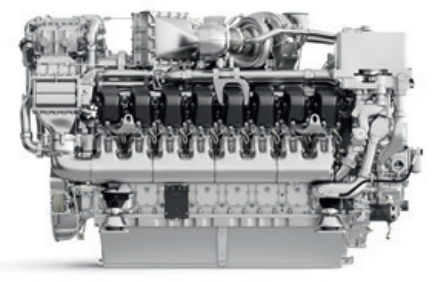

**Series 4000**  
Proven operations reliability in all conditions paired with cutting-edge emissions technology.  
1,000-3,300 kW (1,341-4,425 bhp)

\* For rail specific usage please contact your local partner.



Drive solutions for railcars and locomotives - references

# RAILCARS

Increasing demand for local public transportation brings with it an ongoing need for modern railcars with the latest drive system technology. We – as the experienced specialist – provide the drive systems to support eco-friendly traffic designs. The innovative rail **mtu** PowerPacks meet all the requirements of this high-performance sector, which demands far more than simply a “powerful engine”. Our extremely compact, complete systems are configured to suit individual customer needs and can then be integrated into the vehicle in a quick and easy process, using plug&play.



- 1 Europe | 390 kW / 523 bhp  
Alstom Lint  
Long-term experience and proven designs – over 2,000 **mtu** PowerPacks Series 1800 have been successfully deployed for the railcar platform
- 2 Europe | 565-736 kW / 758-987 bhp  
Pesa Link  
Tailored drive systems and solutions keep 2-car and 3-car train configurations on track and out of the repair shop
- 3 UK | 315 kW / 422 bhp (mechanical)  
150 kW / 201 bhp (electrical)  
Porterbrook  
Development of prototype HybridFLEX railcars fitted with **mtu** Hybrid PowerPack Series 1800 drive systems for clean, quiet hybrid-electric operation
- 4 Russia, Serbia | 360 kW / 483 bhp  
RZD and Serbian Railway  
Metrovagonmash trains are equipped with highly reliable and robust **mtu** PowerPacks Series 1800

# LOCOMOTIVES

They are in continuous use, day after day, and prove their reliability on every continent and over thousands of kilometers. They prove their worth in heavy goods operations just as much as at high speeds on long-haul passenger routes. Long maintenance intervals, maintenance-friendly design and low specific consumption figures all contribute to keeping overall life-cycle-costs low and are thus important factors in the economically efficient running of rail vehicles.



- 1 Europe, Middle East, Asia | 1,500-2,400kW / 2,012-3,218 bhp  
Siemens Mobility  
Our lightweight modular drives power more than 400 EuroRunner, Vectron DE and Dual Mode locomotives around the world
- 2 Europe | 1,200-1,800 kW / 1,609-2,413 bhp  
Vossloh DE12 and DE18  
204 industrial locomotives with modular drive and **mtu** Series 4000 diesel engine designs
- 3 Czech Republic | 2,200 kW / 2,950 bhp  
CZ LOKO  
Much more fuel efficient and reliable – 28 locomotives repowered for 2M62UM freight trains
- 4 Argentina | 2,200 kW / 2,950 bhp  
CRRC  
Designed for the long haul – 107 freight locomotives equipped with **mtu** 16V 4000 R43 diesel engines





Drive solutions for railcars

# POWERPACKS – COMPACT, COMPLETE AND COST-EFFICIENT.

What do you call an innovative drive system that combines all of the elements in one compact and efficient unit? We call it a PowerPack. Specially developed for underfloor or roof installation and available for diesel-electric, diesel-mechanical, diesel-hydraulic as well as hybrid drives, the system features an extremely flat design.

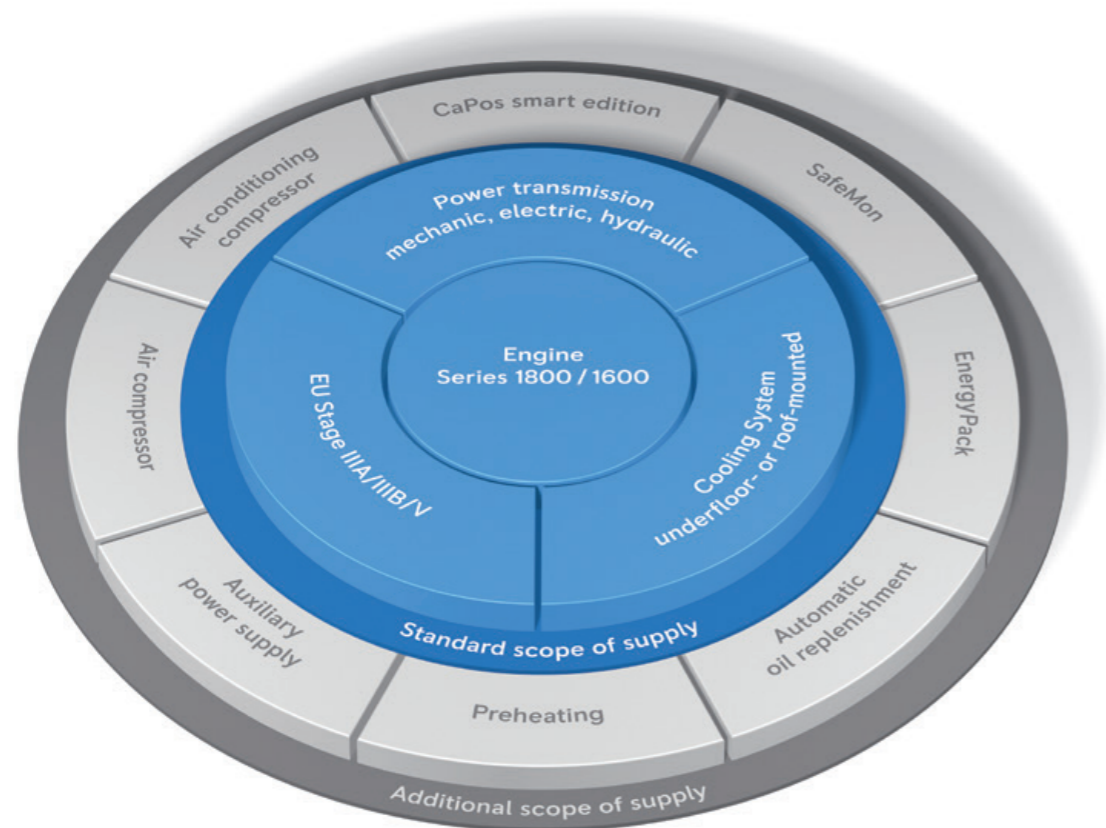

**The power of one**

With over 1,000 successful rail installations, the **mtu** PowerPack Series 1600 and 1800 is the best example of proven performance reliability – and clean performance at that. As complete, ready-to-use drive system, the engine with integrated exhaust gas aftertreatment

fulfills the current EU railcar emission legislation standards. All rolled into one together with a power transmission and cooling system, the low weight unit is a perfect fit for railcars and special-purpose vehicles.

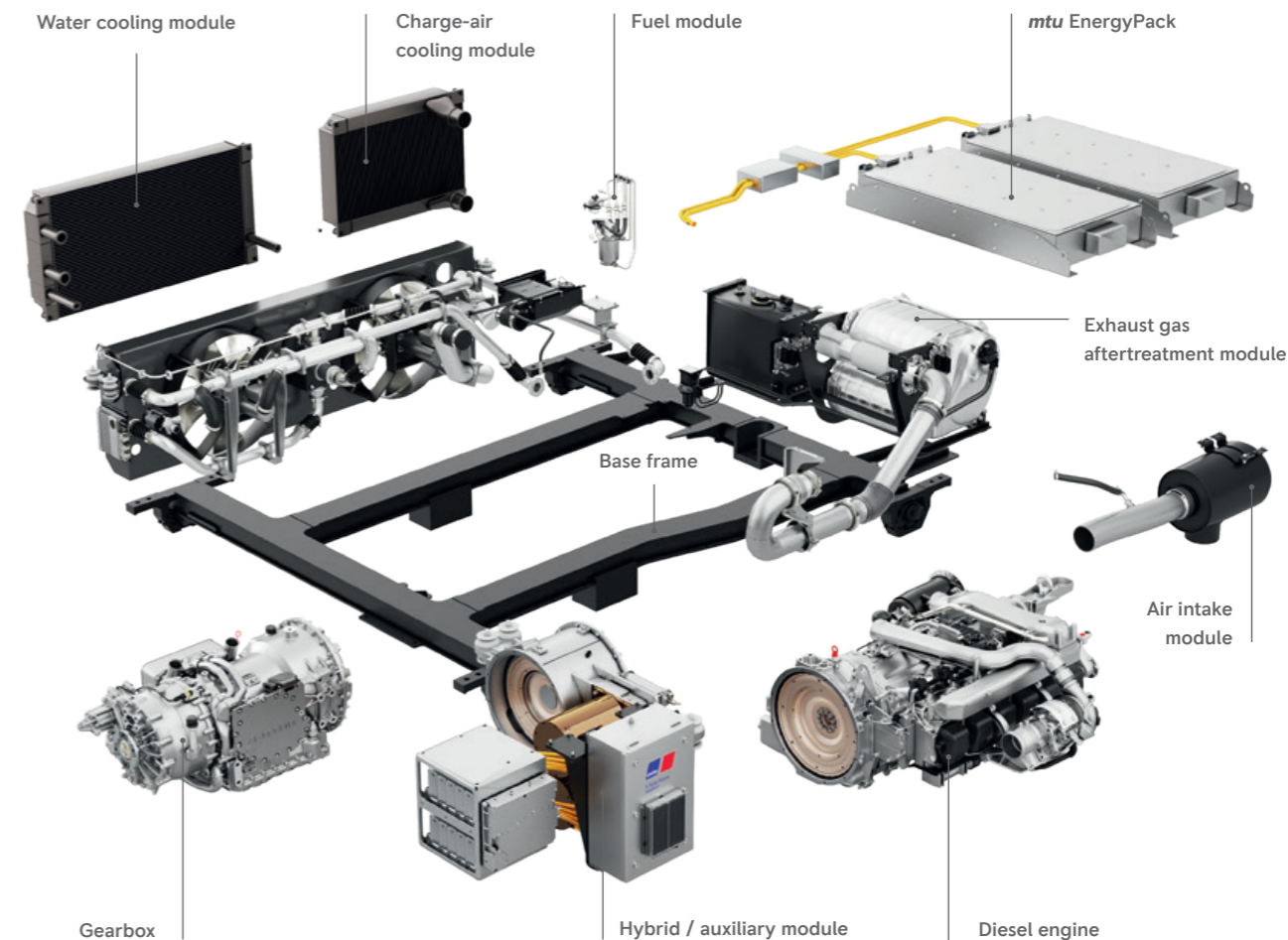

**Plug & play ready**

Quick, easy installation and removal for maintenance

**Cost savings**

Return on investment already begins with the installation

**Compact design & low weight**

Decades of experience in optimizing weight and design

**Engine monitoring**

All functions are monitored by an electronic engine-management and automation system

**System flexibility**

Optimum solution for every requirement - for both hardware and automation

**Eco-friendly**

Internal combustion technologies as well as aftertreatment solutions for lower emissions

**Standards compliant**

Meets US EPA Tier 3, 4i, EU Stage IIIA, IIIB and V standards

**All from one source**

From project kick-off over the entire lifecycle, we are your reliable partner



Drive solutions for push-pull trains and locomotives

# SYSTEM SOLUTIONS WITH SERIES 4000: ALL-ROUND OVERACHIEVERS

To characterize the **mtu** system solutions with Series 4000 as overachievers is almost an understatement. Talk about durability, dependability and clean operational efficiency. Since 1996, these diesel engines have been installed in well over 3,000 railway applications worldwide.

#### **mtu system solutions with Series 4000 benefits**

- Simple, single-frame engine and generator installation
- Perfect system component integration based on:
  - Complete torsional vibration analysis for the entire system
  - Calculation of vibration impact on locomotive performance
  - Optimized engine and generator alignment
- Excellent efficiency through common rail fuel injection and advanced engine control
- Superb emissions values: eliminates over 90% of particulates
- Development, commissioning and service warranty all handled by one source

1 Generator

2 Exhaust gas aftertreatment solution

3 Engine

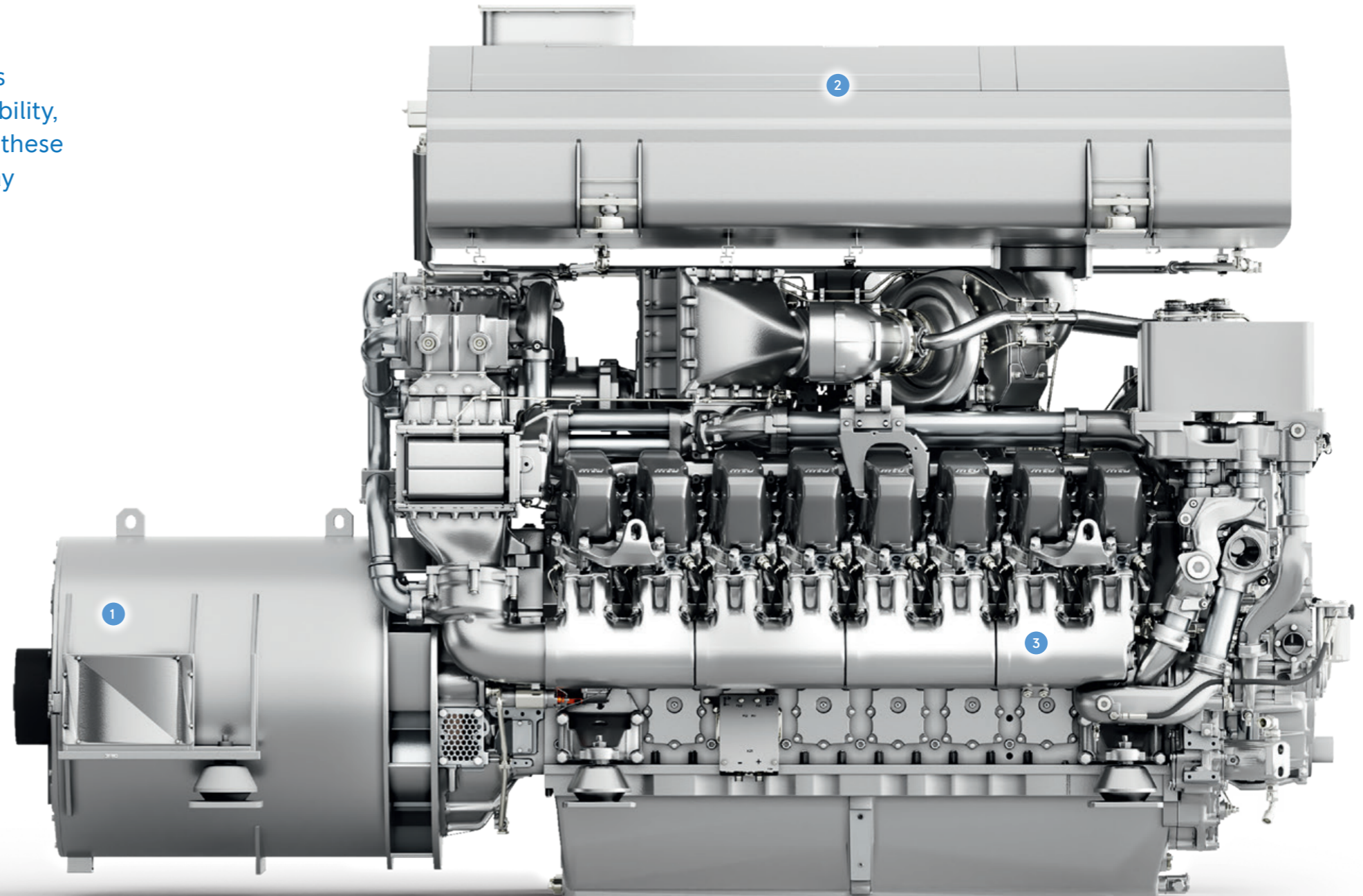



Performance overview

# ENGINES AND POWERPACKS

PowerPacks for roof and underfloor installation

System solutions and Engines for engine room installation



PowerPack with Series 1800



PowerPack with Series 1600



Series 1300\*

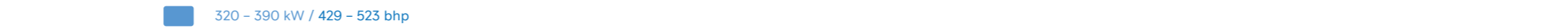

Series 1500\*

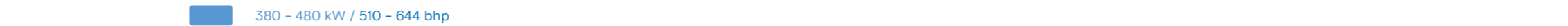

Series 1600 / PowerPack with Series 1600



Series 2000\* / System solutions with Series 2000\*

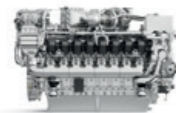
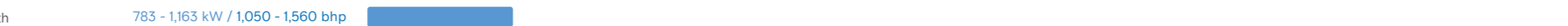

Series 4000 / System solutions with Series 4000

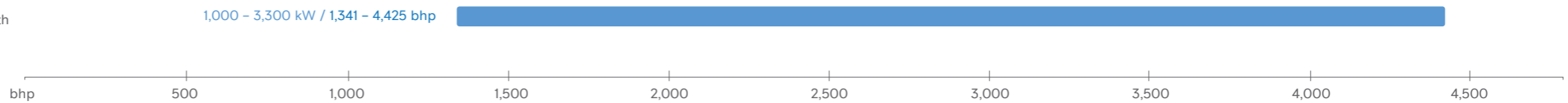

\* For rail specific usage please contact your local partner.



Automation solutions

# DRIVE SYSTEM CONTROL.

# 04

Serving as the operational brain, the PowerControl Automation system monitors and controls the drive system, its components.

PowerControl Automation continually monitors the entire drive system, ensuring maximum drive power availability while optimizing performance efficiency, fuel consumption and emissions reduction – for all types of railcars and in all types of climatic environments.

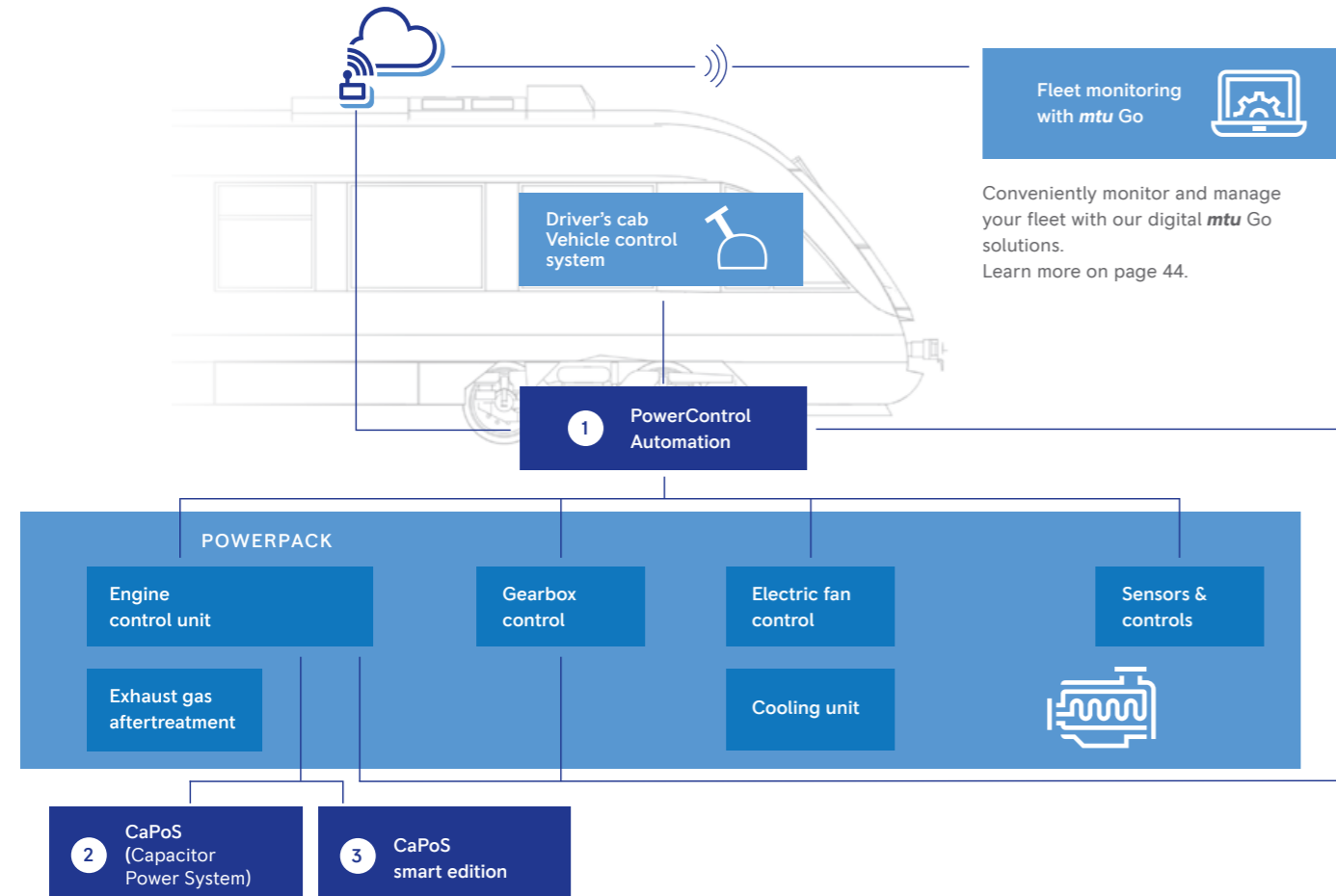

Fleet monitoring with *mtu Go*

Conveniently monitor and manage your fleet with our digital *mtu Go* solutions. Learn more on page 44.

# ENHANCED AUTOMATION FUNCTIONS.

Designed as a modular platform that easily integrates with wide-ranging rail drive control systems, PowerControl Automation functions can be further enhanced with the optional systems CaPoS and CaPoS smart edition.

### CaPoS

Innovatively optimizing cold start-up behaviour, the capacitor power system CaPoS marks a great improvement over conventional starter batteries.

### CaPoS smart edition

Featuring an integrated starter with 24V onboard, the CaPoS smart edition is ideal for the heavy duty start-up tasks of Series 1600, 1800 and 4000 engines.

Implemented safety functions

SIL 1

- Avoidance of unwanted traction
- Protection against overspeeds



SIL 2

- Safe shutdown of the PowerPack, if required (Emergency stop)
- Safe uncoupling

Automation system	1 PowerControl Automation	2 CaPoS (capacitor power system)	3 CaPoS smart edition
Descriptions	Lets you digitally monitor and maximize the performance and safety of your entire fleet.	Innovatively optimizes cold start-up behaviour, replacing conventional starter batteries.	Capacitor power system designed specifically for heavy duty tasks such as 24V DC starting sequences.
Advantages at a glance	<ul style="list-style-type: none"> <li>– Complete, high-connectivity automation control solution</li> <li>– Easy to integrate and scalable for wide-ranging applications</li> <li>– For new rolling stock and repowering</li> <li>– Monitors all critical operational functions of the entire PowerPack</li> </ul>	<ul style="list-style-type: none"> <li>– Optimized cold-starting properties</li> <li>– Autonomous, modular and maintenance-free design</li> <li>– Low lifecycle costs</li> <li>– Electrical system voltage: 16V DC – 154V DC</li> <li>– CAN interface</li> </ul>	<ul style="list-style-type: none"> <li>– Stand-alone component with integral charger</li> <li>– Optimized cold-starting capabilities</li> <li>– Autonomous, modular and maintenance-free design</li> <li>– Low lifecycle costs</li> <li>– 24V DC onboard voltage</li> <li>– Integrated DC-/DC converter for automatic recharging</li> <li>– IP66 protection</li> </ul>
	Available for rail engines and PowerPacks: Series 1600, 1800 & 4000	For Locomotives	For PowerPacks





## Repowering solutions

# ECONOMIC ALTERNATIVES.

Repowering existing railcars and locomotives with **mtu** engines is an economically sound alternative to new purchases. Installing a modern **mtu** diesel engine and systems offers many benefits, including low fuel consumption, reduced downtime, long service intervals and low maintenance. They can significantly reduce operating costs and optimize economic value.

Repowering solutions for locomotives and railcars offer a tried and tested economic alternative to placing a new order with four positive effects:

- Using a modern diesel engine reduces operating and maintenance costs while maximizing the economic benefits.
- Legally stipulated exhaust gas emission standards are met and noise levels significantly reduced.
- Vehicle availability and reliability are brought up to the level of a new vehicle.
- The cost of investment is considerably lower than a new vehicle.

Following conversion, the reduced operating costs enable many potential savings:

- Reduction in fuel costs.
- Extended maintenance intervals and minimized costs thanks to new maintenance concept.
- Legal requirements are met by proven combustion technology; lower fuel and oil consumption lead to reduced pollutant emissions, thus benefitting the environment.
- Lower investment costs through reduced reserve locomotive stock.
- Limited downtime thanks to high availability and reliability.

As a rail industry partner with extensive experience, we not only repower engines, but also provide a comprehensive package of other support services:

- From the design phase to drive system implementation – active support and professional engineering at all stages of the repowering project.
- Supply of the latest, extensively tested engines and PowerPacks featuring compact designs and excellent power-to-weight ratios enabling easy installation, even of higher outputs without permissible axle loads being exceeded.

---

1 Czech Republic | 2,200 kW / 2,950 bhp  
CZ LOKO  
Much more fuel efficient and reliable – 28 locomotives repowered for 2M62UM freight trains



Green technologies and fuels

ENGINEERING TODAY  
WHAT YOU'LL NEED  
TOMORROW.

05





## Emission reduction solutions

## CLEAN EFFICIENCY.

Our advanced emission reduction solutions combine key technologies to meet current and future emissions standards as well as reduce fuel consumption. They are designed to ensure smooth system component interaction and clean operational efficiency.

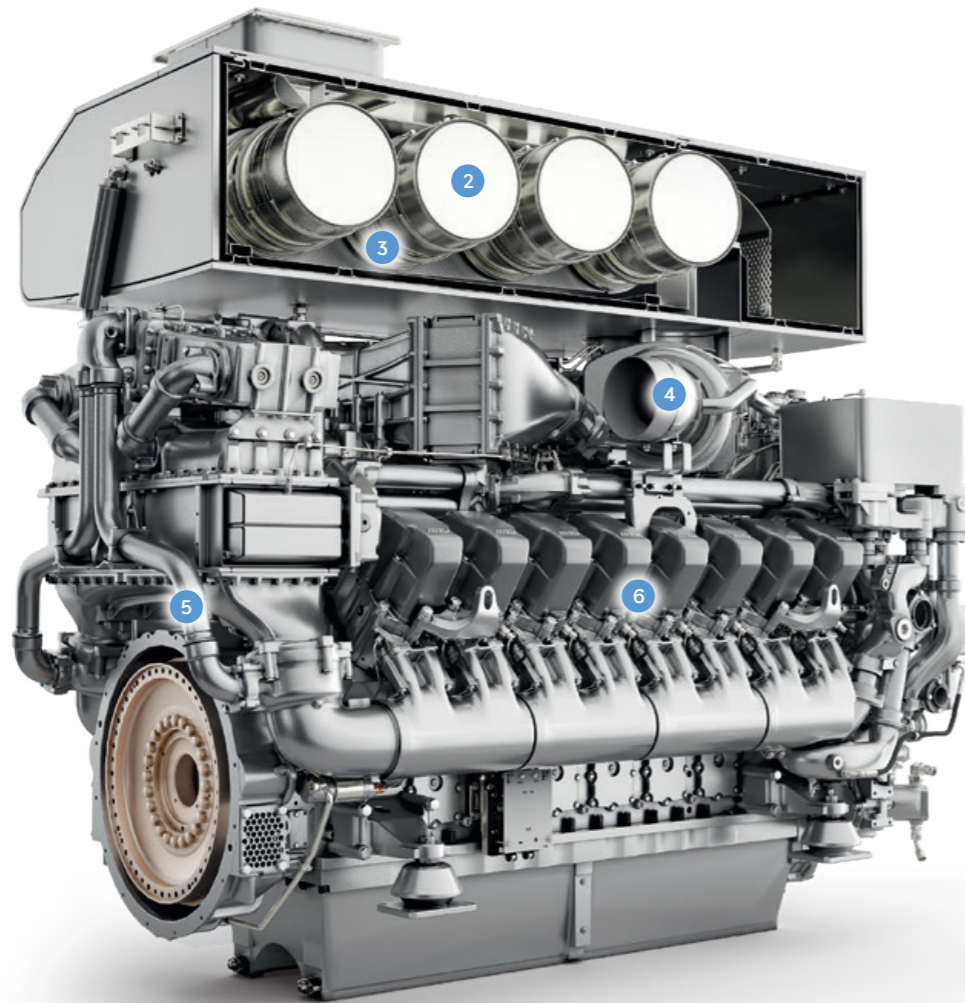

Example based on the Series 4000:  
EU Stage IIIB and V with DPF and DOC.  
IIIA w/o aftertreatment.

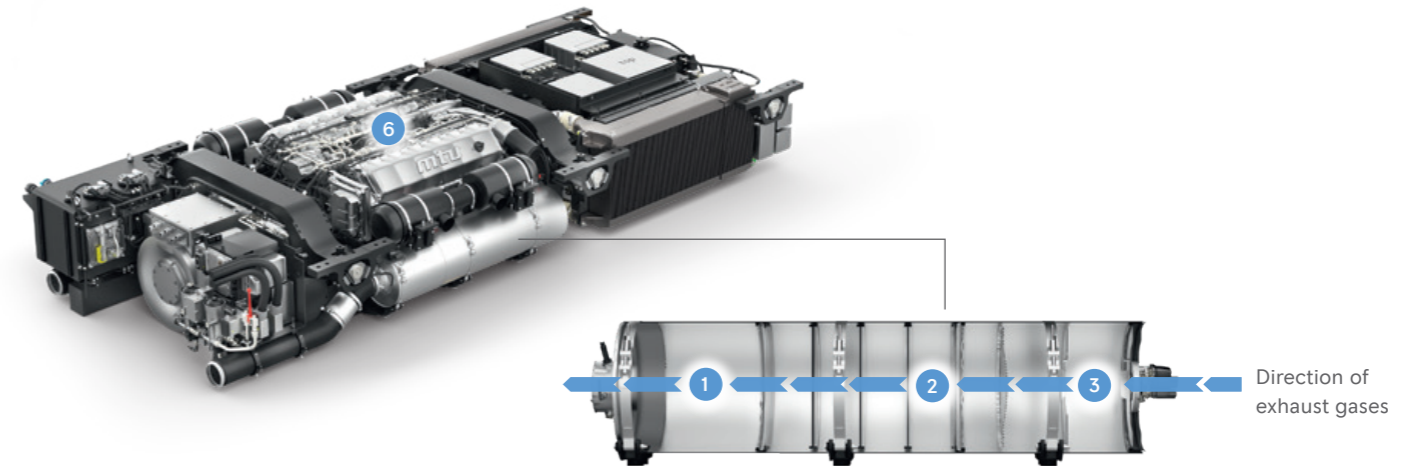
KEY TECHNOLOGIES FOR  
EMISSION REDUCTION.

Example based on the PowerPack Series 1600:  
EU Stage IIIB with SCR,  
EU Stage V with SCR plus DPF and DOC

**1 Selective catalytic reduction (SCR)**

Our SCR solution removes up to 90 percent of nitrogen oxide from exhaust gas. A closed-loop control system prevents ammonia slip during operation. Its fuel and space-efficient design is also very maintenance friendly.

**2 Diesel particulate filter (DPF)**

Our diesel particulate filters reduce soot emissions to levels that, in some cases, are well below statutory limits.

**3 Diesel oxidation catalyst (DOC)**

Easy to install and highly effective in the breakdown of exhaust pollutants – our diesel oxidation catalysts exceed regulatory standards.

**4 Two-stage turbocharging**

With our two-stage turbocharging, engines achieve high output across a wide speed range and superb fuel efficiency. Their space-saving engine integration offers additional benefits.

**5 Exhaust gas recirculation (EGR)**

Modern EGR solutions can reduce nitrogen oxide generation within the cylinder by more than 40%. We have designed a highly compact one that integrates all EGR components. It enables the cost-effective upgrade of rail vehicles for compliance with new emissions standards.

**6 Common rail injection**

Our common rail injection solutions have been enhancing rail engine combustion processes for over 20 years already, making them especially clean and economical.



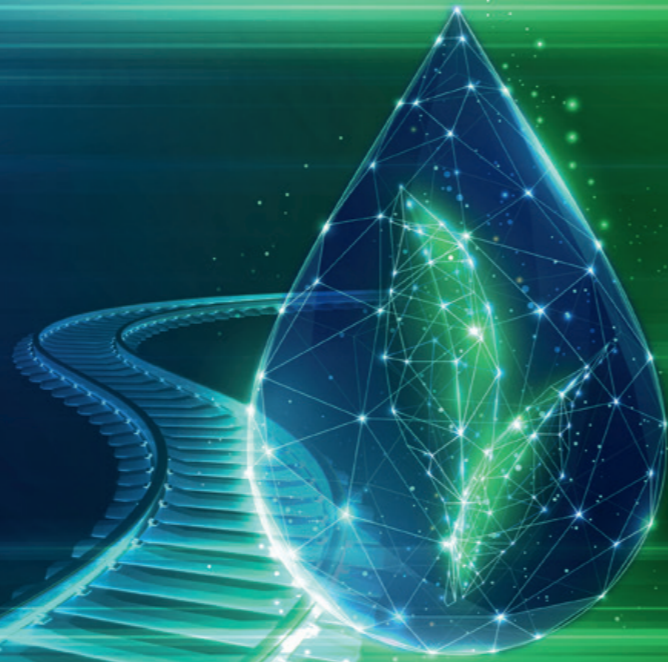

# HVO - YOUR FAST TRACK TICKET TO LOWER EMISSIONS

## Benefits of Hydrotreated Vegetable Oil



### Lower emissions

With HVO, you can significantly reduce your emissions already today using your existing **mtu** diesel engines. Take a look at our numbers: Up to 90% reduction for CO<sub>2</sub>, ~40% reduction for particle matter (~50-80% PM reduction in power generation applications) and ~8% reduction for NO<sub>x</sub>.



### No power loss

Our tests with HVO confirm that **mtu** engines perform equally as well when using HVO (as compared to fossil diesel) in terms of maximum power, load acceptance and fuel consumption.



### Shelf life

The storage stability of pure HVO (without 1<sup>st</sup> gen. biodiesel = FAME) is significantly better than that of pure FAME, HVO/FAME mixtures or even fossil diesel, making it even more attractive to emergency power system operators.



### Drop-in Fuel

HVO is a drop-in fuel, which means that there are generally no adaptations needed to the diesel genset hardware and software (fuel can be blended with fossil diesel in all proportions or pure - 100% concentration).



Interested to find out more about HVO?  
Go to our website by scanning the QR Code

HVO belongs to the group of paraffinic diesel fuels (EN15940 & ASTM D975). This renewable fuel is produced by hydrotreatment process and is already tested and approved for many **mtu** engines and systems. With HVO you can save significantly on emissions already today using your existing diesel systems.



### Properties

HVO is a clear and colourless liquid with a density slightly below that of diesel. Therefore, HVO exhibits a higher cetane number, when compared to the fossil counterpart and thus burns more efficiently, cleanly and with significantly reduced soot production.

### Availability

The excellent ISCC-certified HVO product of our fuel supply partner Neste called "Neste MY Renewable Diesel" is available in Germany, Finland, the Baltic countries, Sweden, Denmark, Belgium, the Netherlands and the US.

### Production

HVO as a fuel is obtained by processing organic materials such as vegetable oils, animal fats or cultivated food crops. In the production from plant materials, an almost closed carbon cycle is created. As a plant, the raw material absorbs CO<sub>2</sub> from the atmosphere and thus reduces the effect on the CO<sub>2</sub> balance through subsequent use in the combustion engine. Thanks to smart and long-term resource management, food security in the regions where the plants are grown is not jeopardized, nor is deforestation promoted.

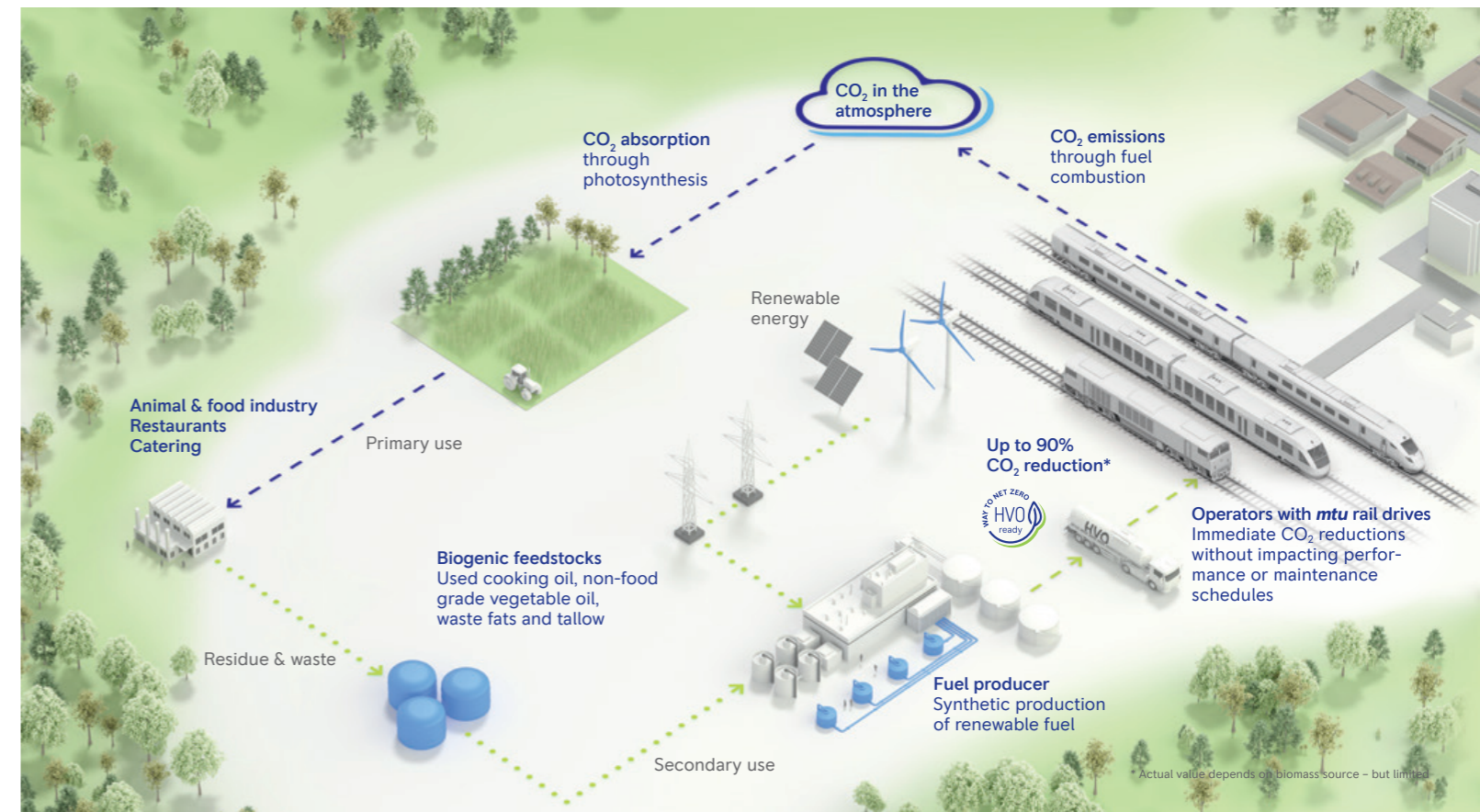

\*Actual value depends on biomass source - but limited



Emission reduction solutions

# SERIES EMISSIONS CERTIFICATIONS.

\* EU IIIA type approved. Under special preconditions certification available on request.  
\*\* For rail specific usage please contact your local partner.

Engine model	Emissions standards						
	Emission optimized w/o certificate	UIC IIIA	EU Stage IIIA compliant	EU Stage IIIB compliant	EU Stage V	EPA Tier 3 compliant	EU Nonroad St V (2016/1628) + EPA Nonroad T4
PowerPacks for roof and underfloor installations							
PowerPack Series 1800			■	■	■	■	
PowerPack Series 1600				■	■		
System solutions and engines for engine room installation							
Series 1300**							■
Series 1500**							■
Series 1600				■	■		
12V/16V 2000**	■						
8V/12V/16V/20V 4000 R43*		■	■				
20V 4000 R63		■	■				
12V/16V 4000 R54						■	
12V/16V 4000 R64/74/84				■	■		



# mtu SERVICE SOLUTIONS – A LIFETIME OF VALUE

# 06

Our service solutions for engines and drive systems are designed to maximize performance, extend life, and provide expert support. These solutions are categorized into three main value propositions: Secure, Sustain, and Support.



**Enjoy peace of mind with maximizing asset performance and reducing operational risks**

- Extended coverage
- **mtu** ValueCare Agreements
- Digital solutions

## SECURE



## SUSTAIN

## SUPPORT



**Extending equipment life and reducing costs while protecting the environment**

- Reman/overhaul solutions
- New exchange engine
- Upgrades and refits



**Expert service from a reliable partner to keep operations running smoothly**

- Maintenance & repair
- Genuine spare parts & consumables
- Training
- Support services

## Extended coverage

# PROTECT YOUR INVESTMENT

**mtu** engines and systems – backed by extended coverage – provide invaluable peace of mind beyond the standard warranty.

With extended coverage, you can be assured that the costs of unplanned repairs are covered, with service performed by **mtu**-certified technicians – upholding resale value and ensuring long-term confidence in your **mtu** investment.

### Avoid the unexpected

Extended coverage protects you from the cost of unexpected repairs beyond your standard warranty, with professional service from **mtu**-certified technicians and coverage tailored to your needs. Packages can also be extended up to five years and are fully transferable, enhancing resale value. Coverage includes all materials and labor for troubleshooting, fault clearance, and corrective services to engines and on-engine electronics (excluding gearbox, alternators or similar components). To ensure maximum quality, all repairs are conducted using only genuine **mtu** parts.

### Your benefits:



**Flexible options and local support to suit your needs (e.g. operating hours)**



**100 % genuine parts and components**



**Protection against unexpected repair costs**

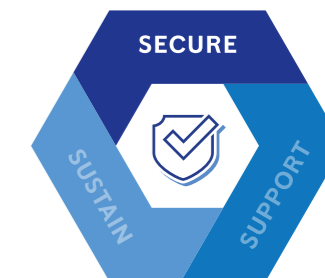



**mtu** ValueCare Agreements

# FOCUS ON YOUR OPERATIONS LEAVE THE REST TO US



You've got a tough job. With us as your partner, you'll get the power, performance and peace of mind to get it done right. The digitally connected power systems of our **mtu** ValueCare Agreements make it easy to keep your business running smoothly and reduce total cost of ownership by maximizing uptime, optimizing lifecycle costs and helping you avoid equipment-related business disruptions through preventive maintenance.

**Service solutions designed around your priorities**

**mtu** ValueCare Agreements make it easy to optimize lifecycle costs, maximize uptime and devote more time and resources to your core business, with tailored solutions to move your business forward.



**Bronze**

Ensure parts availability and price stability

- Digital connectivity (**mtu** Go Connect) and access to **mtu** Go platform
- Automated delivery of parts (preventive) at a predefined rate based on operating hours
- Preventive maintenance labor options to fit your business needs
- Dedicated support for technical issues
- Quarterly reporting of completed and upcoming maintenance and costs
- Annual on-site engine health check by **mtu**-certified technician

**Silver**

Eliminate unexpected maintenance costs

- Proactive maintenance planning, troubleshooting and remote engine health monitoring
- Fixed pricing per operating hour for maintenance and repairs
- Key corrective maintenance components always in-stock at our main warehouses
- 24/7 standby service with remote technical support
- Quarterly reports, including reliability analysis (mean time between failure)

*Silver also includes all benefits of Bronze level*

**Gold**

Maximize operational uptime

- Operational uptime commitment to meet or exceed your availability targets
- Regular supervision by local service partner (e.g. monitoring of parts stock, improvements)
- 24/7 emergency assistance with on-site support
- Monthly reports, including availability and average repair times
- Asset health monitoring
- Annual performance meetings and trend analysis with us to address technical updates, engine fleet data, operational optimization and more

*Gold also includes all benefits of Silver & Bronze levels*





Digital solutions

# YOUR POWER. YOUR SERVICE. CONNECTED.



Rail applications have great demands on engines and drive systems. Ensuring that propulsions are constantly available for optimum use, means making the right maintenance decisions. Our digital solutions enable you to keep track of operating hours, system alarms and maintenance schedules so you can plan service intervals more effectively.

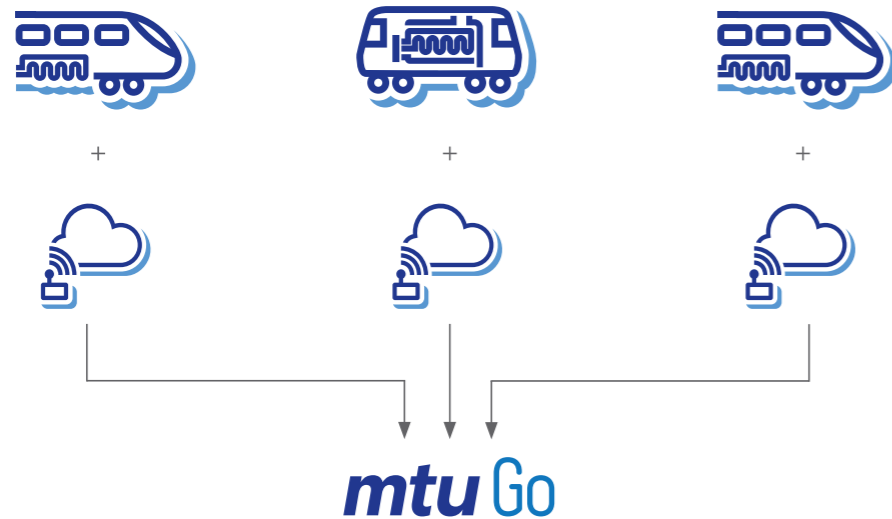

*mtu* Go links your data with our engineering knowledge and experience from thousands of other assets in one global view to provide insights that enrich your business. For details, please scan the QR Code or visit [www.mtu-go.com](http://www.mtu-go.com)

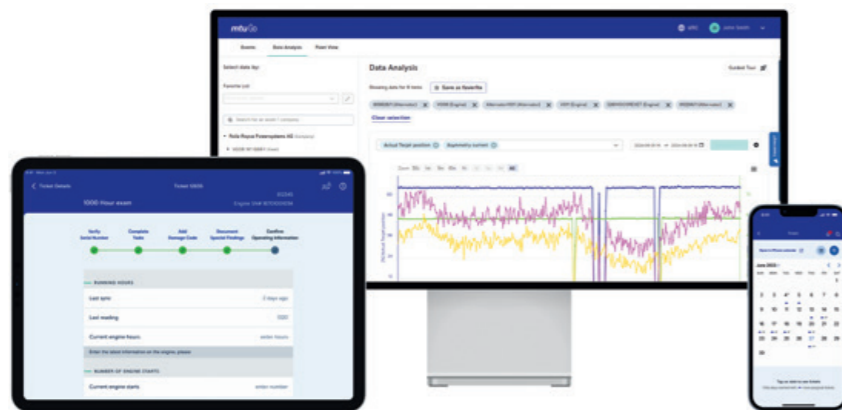

## mtu Go

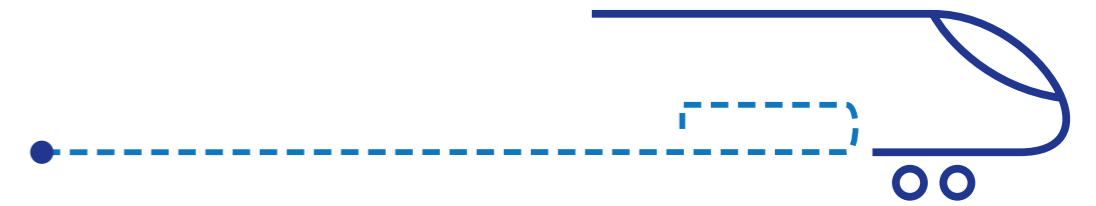

### Delivering actionable insights through digital solutions



**Connect all your equipment**

**Data collection from your fleet, asset, system and engine**

Connectivity is the basis for all the advantages of digitally supported service. Using our edge software connected to the control unit, you and your service network can monitor relevant deviations from the optimum conditions remotely. We offer several ways to collect data, including the creation of interfaces to already existing data sets. In doing so, we always adhere to the highest data privacy and security standards of our industry.

**Access your data**

- Remote monitoring, available for individual assets, as well as complete fleets worldwide
- Data privacy and security to the highest industry standards



**Asset Management**

**Access comprehensive real-time and recent performance data for all assets worldwide, conveniently from one centralized platform**

With the *mtu* Go platform, predefined users, such as on-site technicians or managers, can view the system data and perform initial analyses by using diagnostic tools. By accessing the same information, your service network can provide fast support in handling alarms and planning necessary maintenance together with you.

**Keep track of your data**

- All important data and alarms available at a glance for efficient fleet monitoring
- Intuitive and clear design for easy operation
- Visual comparison of data using the diagnostic tools for initial analyses



**Equipment Health Management**

**Digital solutions for your detailed data analysis on necessary actions**

Supported by *mtu* Go your Service Network is able to analyze all relevant data from your equipment and compare it with data sets from other systems. From this we together can proactively derive recommendations for action. Enhance operational continuity and prevent equipment failure by leveraging proactive monitoring services. Utilize analytics to identify critical states and trends, ensuring optimal availability.

**Packages coming soon (under development)**

- Maintenance Management: Forecast, plan, and execute service tasks based on maintenance schedules and operating hours
- Guided Troubleshooting: providing a user-friendly and guided fault resolving experience for your technicians



Reman/overhaul solutions

# EXCHANGE AND SAVE

Factory remanufactured products deliver the same high standards of performance, service life and quality as new products, along with identical warranty coverage – at a fraction of the cost. And with design and model-related updates, they also feature similar technological advancements. Developed by R&D engineers, the remanufacturing process saves you time and money, while benefiting the environment through the reuse of materials. To help you work efficiently, a wide range of remanufactured parts, engines and systems are available worldwide.

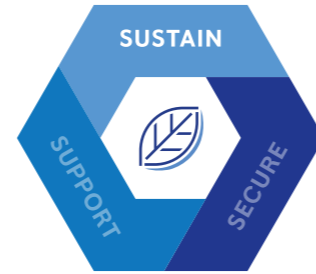

**Reduce lifecycle costs**

As you evaluate your long-term power needs, you must consider a variety of factors. Factory remanufactured products are a smart solution, helping you to reduce the total lifecycle cost of your equipment.

**Save time**

Factory remanufactured products put your equipment back to work faster than an overhaul, which reduces downtime, service time and indirect costs such as storage.

**Our maintain standards**

All products are remanufactured/overhauled to our strict standards by certified technicians at our regional centres. We remanufacture/overhaul parts, engines and/or systems to both original and upgraded factory specifications.

**Protect the environment**

Since remanufacturing is an efficient use of resources and energy, factory remanufactured products benefit the environment as well.

Exchange Process

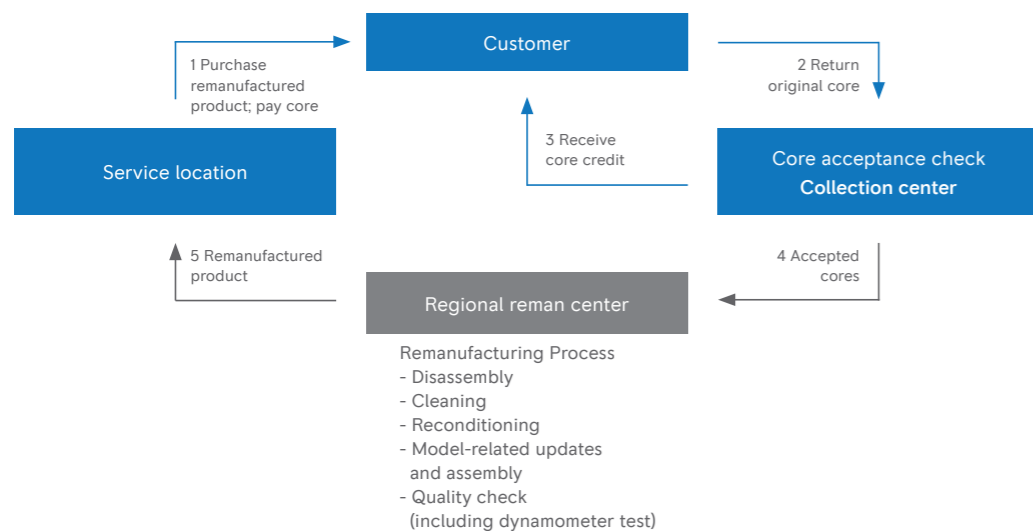

- 1 Customer purchases remanufactured product from local service partner and pays the core deposit.
- 2 Customer's original core is returned to collection center by local service partner for core acceptance check.
- 3 Customer receives core credit based on the core's technical condition.
- 4 Accepted cores are sent to regional reman centers, where the remanufacturing process takes place.
- 5 Remanufactured products are delivered to our service partners and made available for purchase.

Preventive maintenance

# DON'T LET THE UNKNOWN LEAVE YOU UNPREPARED



With large investments, lifecycle costs can be significant. It's often the unforeseen costs lurking below the surface – things like fuel consumption, unplanned downtime and repairs – that have the greatest potential to impact your business. That's why it pays to invest in our superior power systems and plan ahead with preventive maintenance. There's no better way to optimize fuel economy, maximize uptime and avoid the unexpected.

**Optimize fuel economy**

Fuel consumption accounts for up to 90 percent of total lifecycle costs depending on the application—by far one of the most significant costs associated with your equipment. Well-maintained engines deliver industry-leading fuel efficiency, helping you keep fuel costs down over the long term.

**Maximize uptime**

Preventive maintenance services can be planned around your schedule, so your equipment is available when you need it most.

**Avoid the unexpected**

Planned maintenance helps solve problems before they start, helping you avoid unexpected downtime and resolve problems early before they escalate.

**Work with one source**

We keep maintenance simple, safe and efficient. Our factory-approved methods and expert technicians ensure everything is done correctly according to our proprietary preventive maintenance schedules, optimizing the availability of your equipment, reducing lifecycle costs and helping you avoid unforeseen problems.

The importance of preventive maintenance

When preventive maintenance is a high priority.

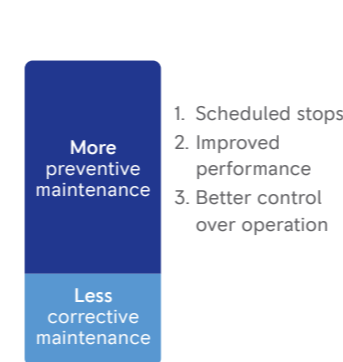

1. Scheduled stops
2. Improved performance
3. Better control over operation

When preventive maintenance is a low priority.

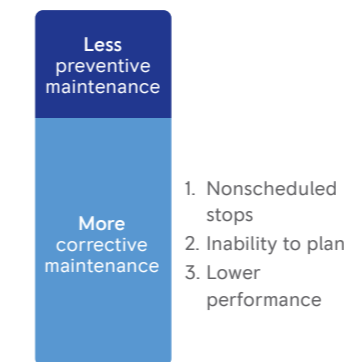

1. Nonscheduled stops
2. Inability to plan
3. Lower performance

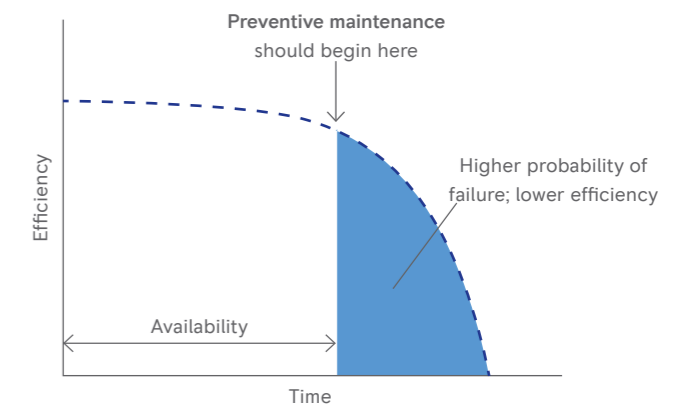

We focus on preventive maintenance to reduce the downtime and added costs of corrective maintenance.

Delaying maintenance increases unexpected failures and decreases performance and fuel economy.



Support services

# DEMAND GENUINE

Only we can guarantee genuine spare parts that are designed, tested and approved specifically for **mtu** engines and systems to reach maximum uptime.



Genuine parts maximize performance, prolong engine life and meet today's strict requirements (e.g. emission regulations), all thanks to years of intensive research and development, quality audits, and progressive modifications — making them the best possible match for your engine and guaranteeing state-of-the-art technological fit. We offer a supply chain management, optimizing your purchasing and ordering processes.

**Take advantage of broad benefits of mtu genuine spare parts:**

- Engineered to secure high engine reliability and availability
- Value sustainability of your equipment / the only parts that live up to our standards
- Factory / OEM warranty coverage incl. professional service support
- Long-term supply solutions through the entire equipment lifetime
- State-of-the-art Parts Logistics Centers

Non-genuine parts are simply not worth the risk of endangering your mission.



# THE VALUE OF PROFESSIONAL TRAINING

Count on our experience and expertise

Correct training is the best way for operators and maintenance technicians to become proficient with **mtu** engines and systems so they can get maximum efficiency from the equipment. It is essential for the reliable functioning of the systems, maintaining the value of the investment and preventing breakdowns.

Whether you need operators to learn how to use the equipment effectively or are developing your own on-site maintenance capabilities, count on our experience and expertise to set you up for success.



Whenever and wherever you need expert support, our specialists are available.

Our global service network of more than 1,200 locations – backed by our cutting-edge parts logistics centers – provides you this assurance. To find your local distributor, visit [www.mtu-solutions.com](http://www.mtu-solutions.com).

Europe, Middle East, Africa +49 7541 90-77777  
Asia/Pacific +65 6860 9669  
North and Latin America +1 248 560 8888

[info@ps.rolls-royce.com](mailto:info@ps.rolls-royce.com)

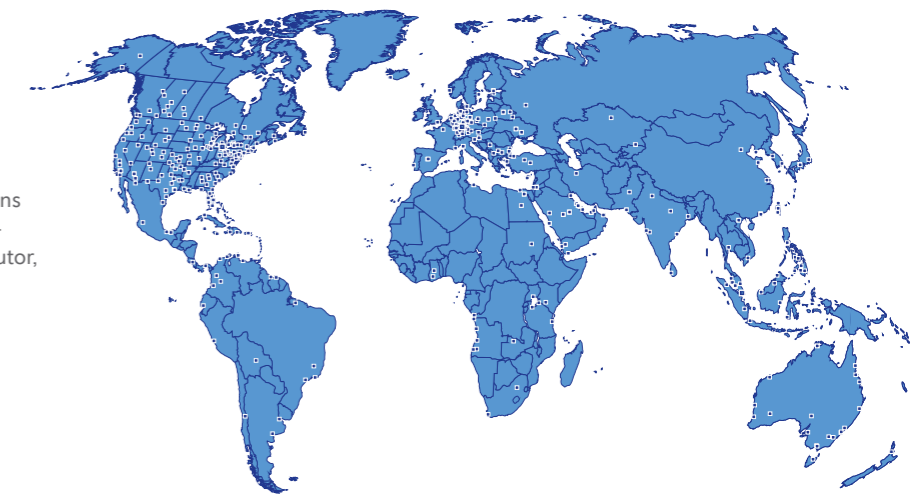

More than 1,200 service locations worldwide.









Stay posted with more powerful information  
and follow **mtusolutions** under:



Rolls-Royce Group  
[www.mtu-solutions.com/rail](http://www.mtu-solutions.com/rail)

The Rolls-Royce name, Rolls-Royce badge and Rolls-Royce monogram logos are registered Trade Marks of Rolls-Royce plc